

***PRE CAST TECHNOLOGY WHICH FULFILS  
THE MODERN REQUIREMENTS.***



*Pre-Cast Compound Wall is Stronger,  
more durable, lean, time saving and  
economical than traditional compound wall.*

## **For Details Contact**

M.Adireddy  
Plant Manager (Production & Marketing)  
**Kapil Avenues and Consultants Pvt.Ltd**  
Mobile: +91 80969 12317, +91 8096910234  
E-mail: [adireddy@kapilhomes.com](mailto:adireddy@kapilhomes.com)  
[kapilavenues@kapilhomes.com](mailto:kapilavenues@kapilhomes.com)



## COMPANY PROFILE

Kapil Pre-cast (Unit of Kapil group) introduce ourselves as the company that cares for quality products. We are manufacturers of Pre Stressed Pre-cast compound wall with different designs, as per customer requirements. These can be used as partition walls for godowns, labour quarters. With the culture of deep dedication to work, determination to succeed, our company today enjoys a premium position among the indigenous class manufacturers.

Our Products are manufactured under stringent norms, the raw materials are procured from reputed manufacturers and suppliers are accepted through rigorous quality control norms. All these enable us to maintain a satisfactory clients.

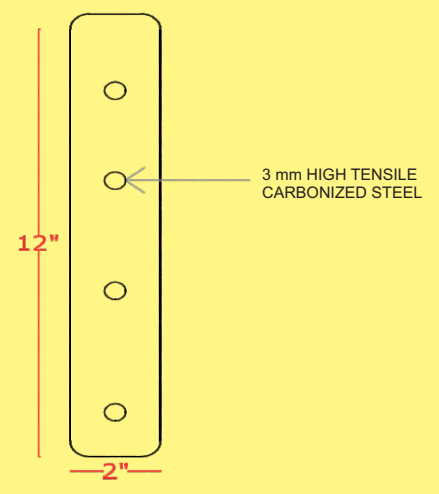
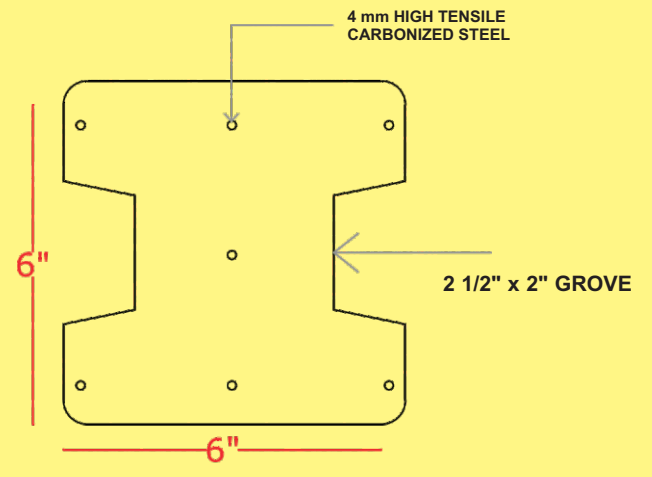
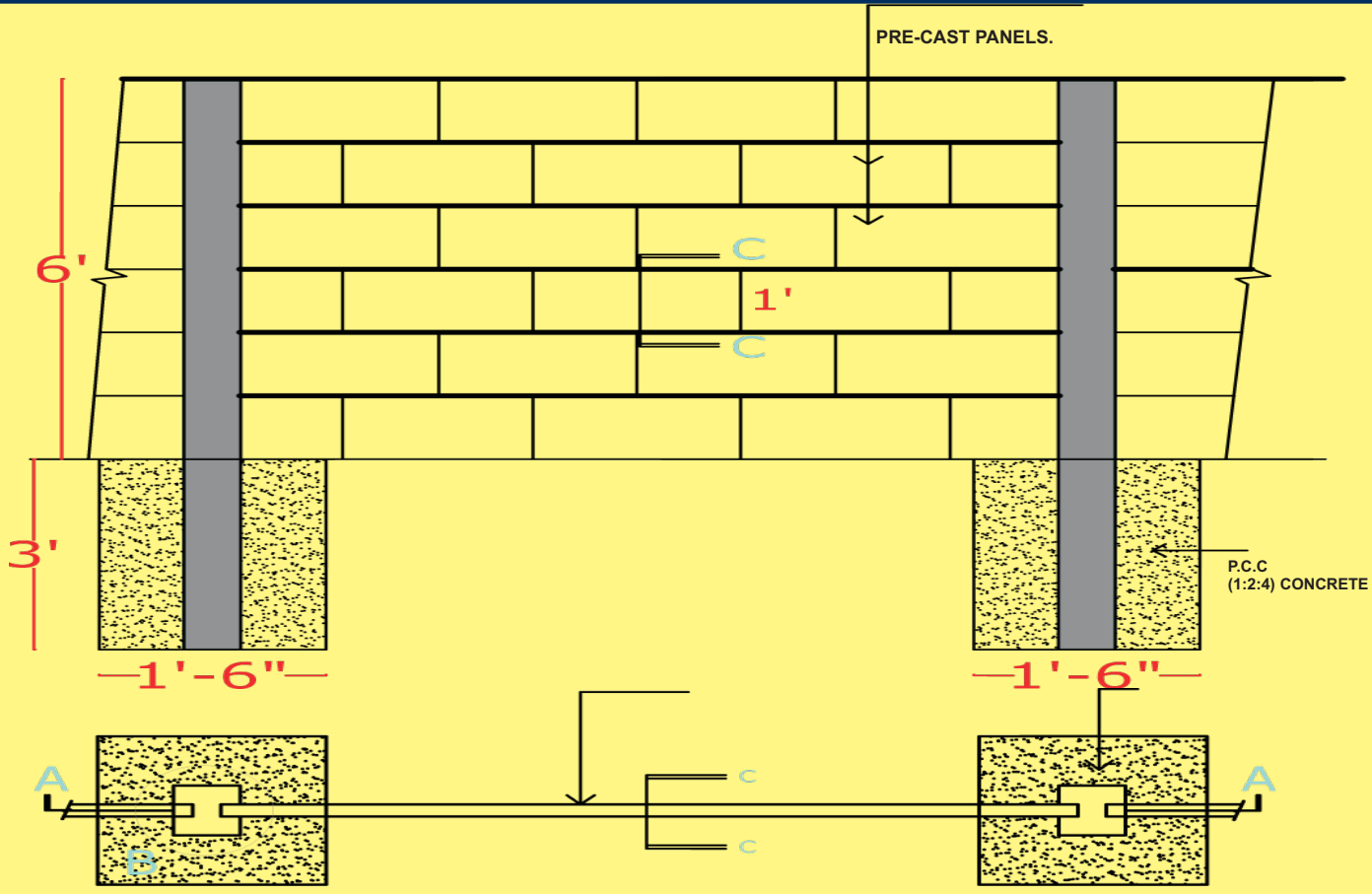

## PRODUCT ADVANTAGES:

- Less space utilized i.e.,space saving.
- Speedy installation.
- Durability.
- Re-Installable.
- Economy compared to conventional products.
- Plastering not required.
- No Foundation Required.



# PRODUCT APPLICATIONS



**Compound Wall**



**Godown / industrial Shed**



**Office Building**



**Security Building**



**Labour Quarter**



**Garden Curbing**

## COMPARISON OF TRADITIONAL BOUNDARY WALL & PRE-STRESS PRE-CAST BOUNDARY WALL (BW)

SN	PROPERTY	TRADITIONAL BOUNDARY WALL	PRE STRESS PRE CAST BOUNDARY WALL	REMARKS
1	Construction Time	100 meter wall requires at least 7 days to construct and another 7 days for water curing	100 meter wall can be constructed in only 2 days	PSPC BW save precious construction time
2	Strength	The weakest part of this wall is its 150 mm thick brick masonry which can be easily broken by ordinary hand tools for theft.	PSPC panels consist of high tensile wire at every 75 mm distance and can cut only by mechanical means.	PSPC BW provides more better security for industrial campus
3	Durability	Less as its depends on the quality of plaster and that depends upon several factors like plaster, its thickness, quality of sand, quality of curing, workmanship etc..	Very high as PSPC panel are made of void less dense high grade concrete and has smooth concrete surface.	PSPC BW has almost NIL maintenance cost.
4	Weight	Approximate 600 kg/RMT	Approximate 205kg/RMT	PSPC BW required small foundations.
5	Repair ability	In case of cover turning failure a large section of BW may damage and require almost new construction as repair and require several week time to repair.	In case of failure only few columns may get damaged and require to be replaced. Almost all the panels can be reused in repair in negligible time	PSPC BW has almost NIL repair cost and fast work ability.
6	Paint	Painting is must, as plastered surface is susceptible to weather decay.	Painting is optional and can only for decorative purpose.	PSPC BW saves painting cost.
7	Re-use	Cannot be re used as entire construction is of permanent type.	Almost 100% panel and 60% columns can be reused.	PSPC BW saves lots of money.
8	Weathering effect	As plaster surface adsorbs moisture, resulting cracks and peels off. It requires periodically re plaster the boundary wall.	There is almost nil moisture absorption as panel surfaces are made of dense concrete and requires no maintenance.	PSPC BW has almost nil maintenance cost.
9	Cleaning	Moisture absorbed in plastered surface attracts dust, fungus, algid; plants etc., and requires periodically cleaning and re-painting.	No special cleaning required, only washing can make your BW new again.	PSPC BW save cleaning cost.

## TECHNICAL DETAILS

### POLE DIMENSIONS:

150 mmx150mm, Length 4 feet to 12 feet  
groove width 60mm and depth 40mm.

### POLE WEIGHT

14 kg/Rft (APPROX)

### POLE REINFORCEMENT:

4mm dia.high tensile carbonized steel  
wire 7 nos..

### PANEL DIMENSIONS:

1 foot wide, 50 mm (2 inch thick)  
7 feet length

### PANEL WEIGHT:

7'.0".X1'.0" Size 77 kg.( APPROX)

### PANEL REINFORCEMENT:

3mm dia. high tensile carbonized  
steel wire 4 nos.

### GRADE OF CONCRETE

M-25 Design max.



Kapil Pre-Cast was established with expertise in Pre-Cast compound wall manufacturing. Kapil Pre-Cast Boundary wall System offer better solution in meeting today's construction requirements.

### Plant Location:

**Kapil Pre-Cast Compound wall** Production Plant  
Saptagiri Colony (Kail Homes) Railapur Village,  
Near Nagaluru Village, Medchal, Rangareddy Dist.  
Hyderabad, Andhra Pradesh, India.  
Contact: 08096912317, 08096910234.

Kapil Avenues and Consultants Pvt.Ltd  
Plot No 16, Simhapuri Colony, West Marredpally,  
Secunderabad - 500026. Andhra Pradesh, India.

